

Flush pressure transmitter

For viscous and solids-containing media

Model S-11

WIKA data sheet PE 81.02



Applications

- Machine building
- Hydraulic aggregates
- General industrial applications
- Food and beverage industry

Special features

- High-quality product
- Many configurations possible
- Flush process connection
- Large stocks for short delivery times
- Vacuum-tight



Fig. left: Pressure transmitter model S-11
Fig. right: Pressure transmitter model S-11 with cooling element

Description

Specialist for viscous and solids-containing media

The model S-11 pressure transmitter with flush diaphragm has been specifically designed for the measurement of viscous, paste-like, adhesive, crystallising, particle-laden and contaminated media, which would clog the pressure channel of conventional process connections.

Through its optimised design, the flush process connection enables the cleanability of the wetted diaphragm to be integrated into the process. Low-maintenance and trouble-free pressure measurement is thus also guaranteed in critical applications with frequently changing media.

High accuracy, a robust design, high-quality workmanship and the high flexibility of configuration are key features of the model S-11.

Flush process connection

All process connections of the flush pressure transmitter are made of stainless steel, all welded and isolate the process medium from the pressure measuring instrument via a positive seal. A reliable, dead-space free sealing between the process connection and the measuring medium is thus assured.

For high medium temperatures of up to 302 °F (150 °C), the pressure transmitter is also available with an integrated cooling element.

Specifically for the food and beverage industry, a version with internal system fill fluid in accordance with FDA 21 CFR 178.3750 can be chosen.

Measuring ranges

Gauge pressure								
bar	Measuring range	0 ... 0.1	0 ... 0.16	0 ... 0.25	0 ... 0.4	0 ... 0.6	0 ... 1	0 ... 1.6
	Overpressure limit	1	1.5	2	2	4	5	10
	Measuring range	0 ... 2.5	0 ... 4	0 ... 6	0 ... 10	0 ... 16	0 ... 25	0 ... 40
	Overpressure limit	10	17	35	35	80	50	80
psi	Measuring range	0 ... 60	0 ... 100	0 ... 160	0 ... 250	0 ... 400	0 ... 600	
	Overpressure limit	120	200	320	500	800	1,200	
	Measuring range	0 ... 15	0 ... 20	0 ... 30	0 ... 50	0 ... 60	0 ... 100	0 ... 150
	Overpressure limit	145	145	145	240	240	500	500
psi	Measuring range	0 ... 160	0 ... 200	0 ... 250	0 ... 300	0 ... 400	0 ... 500	0 ... 600
	Overpressure limit	1,160	1,160	1,160	1,160	1,160	1,160	1,160
	Measuring range	0 ... 750	0 ... 1,000	0 ... 1,500	0 ... 2,000	0 ... 3,000	0 ... 5,000	0 ... 6,000
	Overpressure limit	1,740	1,740	2,900	4,600	7,200	11,600	11,600

Absolute pressure								
bar	Measuring range	0 ... 0.25	0 ... 0.4	0 ... 0.6	0 ... 1	0 ... 1.6	0 ... 2.5	0 ... 4
	Overpressure limit	2	2	4	5	10	10	17
	Measuring range	0 ... 6	0 ... 10	0 ... 16				
	Overpressure limit	35	35	80				
psi	Measuring range	0 ... 15	0 ... 25	0 ... 50	0 ... 100	0 ... 250		
	Overpressure limit	72.5	145	240	500	1,160		

Vacuum and +/- measuring range						
bar	Measuring range	-0.6 ... 0	-0.4 ... 0	-0.25 ... 0	-0.16 ... 0	-0.1 ... 0
	Overpressure limit	4	2	2	1.5	1
	Measuring range	-1 ... 0	-1 ... +0.6	-1 ... +1.5	-1 ... +3	-1 ... +5
	Overpressure limit	5	10	10	17	35
psi	Measuring range	-1 ... +9	-1 ... +15	-1 ... +24		
	Overpressure limit	35	80	50		
	Measuring range	-30 inHg ... 0	-30 inHg ... +30	-30 inHg ... +60	-30 inHg ... +100	-30 inHg ... +160
	Overpressure limit	72.5	240	240	500	1,160
psi	Measuring range	-30 inHg ... +200	-30 inHg ... +300			
	Overpressure limit	1,160	1,160			

The given measuring ranges are also available in mbar, MPa and further units.

Vacuum tightness

Yes

Output signals

Signal type	Signal
Current (2-wire)	4 ... 20 mA
Current (3-wire)	0 ... 20 mA
Voltage (3-wire)	DC 0 ... 10 V DC 0 ... 5 V

Other output signals on request.

Depending on the signal type the following loads apply:

Current (2-wire)	$\leq (\text{power supply} - 10 \text{ V}) / 0.02 \text{ A}$
Current (3-wire)	$\leq (\text{power supply} - 3 \text{ V}) / 0.02 \text{ A}$
Voltage (3-wire)	$> \text{max. output signal} / 1 \text{ mA}$

Voltage supply

Power supply

The power supply depends on the selected output signal

4 ... 20 mA (2-wire)	DC 10 ... 30 V
0 ... 20 mA (3-wire)	DC 10 ... 30 V
DC 0 ... 10 V	DC 14 ... 30 V
DC 0 ... 5 V	DC 10 ... 30 V

Reference conditions (per IEC 61298-1)

Temperature

59 ... 77 °F (15 ... 25 °C)

Atmospheric pressure

12.47 ... 15.37 psi (860 ... 1,060 mbar)

Humidity

45 ... 75 % r. h.

Power supply

DC 24 V

Mounting position

Calibrated in vertical mounting position with process connection facing downwards.

Accuracy data

Accuracy at reference conditions

Standard	$\leq \pm 0.5 \%$ of span
Option	$\leq \pm 0.25 \%$ of span ¹⁾

1) Only for measuring ranges ≥ 0.25 bar

Including non-linearity, hysteresis, zero offset and end value deviation (corresponds to measured error per IEC 61298-2). Calibrated in vertical mounting position with process connection facing downwards.

Non-linearity (per IEC 61298-2)

$\leq \pm 0.2 \%$ of span BFSL

Non-repeatability

$\leq \pm 0.1 \%$ of span

Temperature error in rated temperature range

Rated temperature range:

32 ... 176 °F (0 ... 80 °C)

Mean temperature coefficient of zero point:

Measuring range > 0.25 bar $\leq 0.2 \%$ of span/10 K

Measuring range ≤ 0.25 bar $< 0.4 \%$ of span/10 K

Mean temperature coefficient of span:

$\leq 0.2 \%$ of span/10 K

Long-term drift

$\leq \pm 0.2 \%$ of span/year

Adjustability of zero point and span

Adjustment is made using potentiometers inside the instrument.

Not possible for cable outlet with ingress protection IP 68.

Zero point $\pm 5 \%$

Span $\pm 5 \%$

Time response

Settling time

≤ 10 ms

Operating conditions

Ingress protection (per IEC 60529)

The ingress protection depends on the type of electrical connection.

Electrical connection	Ingress protection
Angular connector DIN 175301-803 A	IP 65
Circular connector M12 x 1 (4-pin)	IP 67
Cable outlet	
■ Standard	IP 67
■ Option	IP 68 ²⁾

2) Adjustability of zero point and span not possible.

The stated ingress protection only applies when plugged in using mating connectors that have the appropriate ingress protection.

Vibration resistance

Process connections without cooling element:
20 g (IEC 60068-2-6, under resonance)

Process connections with cooling element:
10 g (IEC 60068-2-6, under resonance)

Shock resistance

Process connections without cooling element:
1,000 g (IEC 60068-2-27, mechanical)

Process connections with cooling element:
400 g (IEC 60068-2-27, mechanical)

Permissible temperature ranges

Also meets EN 50178, tab. 7, operation (C) 4K4H, storage (D) 1K4, transport (E) 2K3.

Process connections without cooling element		
Medium		
■ Standard	-30 ... +100 °C	-22 ... +212 °F
■ Option	-30 ... +125 °C	-22 ... +257 °F
Ambient	-20 ... +80 °C	-4 ... +176 °F
Storage	-40 ... +100 °C	-40 ... +212 °F

Process connections with cooling element		
Medium	-20 ... +150 °C	-4 ... +302 °F
Ambient	-20 ... +80 °C	-4 ... +176 °F
Storage	-40 ... +100 °C	-40 ... +212 °F

Electrical connections

Short-circuit resistance

S₊ vs. U₋

Reverse polarity protection

U₊ vs. U₋

Overvoltage protection

DC 36 V

Insulation voltage

DC 500 V with NEC class 02 voltage supply (low voltage and low current max. 100 VA even under fault conditions)

Connection diagrams

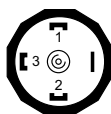
Angular connector DIN 175301-803 A		
	2-wire	3-wire
	U ₊ 1	1
	U ₋ 2	2
	S ₊ -	3
Wire cross-section max. 1.5 mm ² (AWG 16) Cable diameter 6 ... 8 mm (0.24 ... 0.31")		

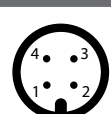
Circular connector M12 x 1 (4-pin)		
	2-wire	3-wire
	U ₊ 1	1
	U ₋ 3	3
	S ₊ -	4

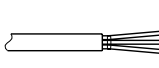
Cable outlet		
	2-wire	3-wire
	U ₊ brown	brown
	U ₋ green	green
	S ₊ -	white
	Shield grey	grey
Wire cross-section 6 x 0.5 mm ² (AWG 20) Cable diameter 6.8 mm (0.27") Cable lengths 1.5 m, 3 m, 5 m, 10 m, 15 m (4.9 ft, 9.8 ft, 16.4 ft, 32.8 ft, 49.2 ft)		

Other connections on request.

Process connections

Process connection	Available measuring ranges	
G ½ B flush ³⁾	0 ... 2.5 to 0 ... 600 bar	0... 50 to 0 ... 6,000 psi
G 1 B flush ³⁾	0 ... 0.1 to 0 ... 1.6 bar	0 ... 15 psi
Hygienic G 1 B flush (in accordance with 3-A Sanitary Standards)	0 ... 0.1 to 0 ... 25 bar	0 ... 15 to 0 ... 300 psi, respectively

3) Process connection also available with cooling element.

Cooling elements

For higher medium temperatures process connections with cooling element are available (see "Operating conditions").

Sealing

Process connection	Max. medium temperature	Sealing material and max. pressure limitation		
		Standard	Option 1	Option 2
without cooling element	up to 212 °F (100 °C)	NBR up to 8,700 psi (600 bar)	FKM/FPM ⁴⁾ up to 8,700 psi (600 bar)	EPDM up to 2,900 psi (200 bar)
	up to 257 °F (125 °C)	NBR up to 8,700 psi (600 bar)	FKM/FPM ⁴⁾ up to 5,800 psi (400 bar)	EPDM up to 2,900 psi (200 bar)
with cooling element	up to 302 °F (150 °C)	FKM/FPM ⁴⁾ up to 4,350 psi (300 bar)	EPDM up to 2,900 psi (200 bar)	-
Hygienic	up to 302 °F (150 °C)	EPDM up to 2,900 psi (200 bar)	-	-

4) Minimum permissible medium and ambient temperature -20 °C / -4 °F

The sealings listed under "Standard" are included in the delivery.

Materials

Wetted parts

- Stainless steel
- For sealing materials see "Process connections"

Non-wetted parts

Internal system fill fluid	
Standard	Synthetic oil
Option	Food-compatible system fill fluid per FDA 21 CFR 178.3750

CE conformity

Pressure equipment directive

97/23/EC

EMC directive

2004/108/EC, EN 61326 emission (group 1, class B) and interference immunity (industrial application)

Approvals

- **CSA**, safety (e.g. electr. safety, overpressure, ...), Canada
- **GOST-R**, import certificate, Russia
- **GOST**, metrology/measurement technology, Russia
- **3-A**⁵⁾, food, USA
- **CRN**, safety (e.g. electr. safety, overpressure, ...), Canada

5) 3-A only for instruments with hygienic process connection G 1 B

Approvals, see website

Dimensions in mm (inch)

Pressure transmitter

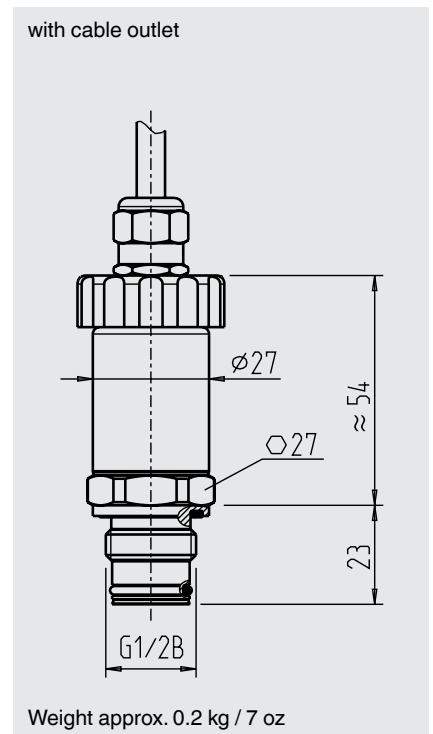
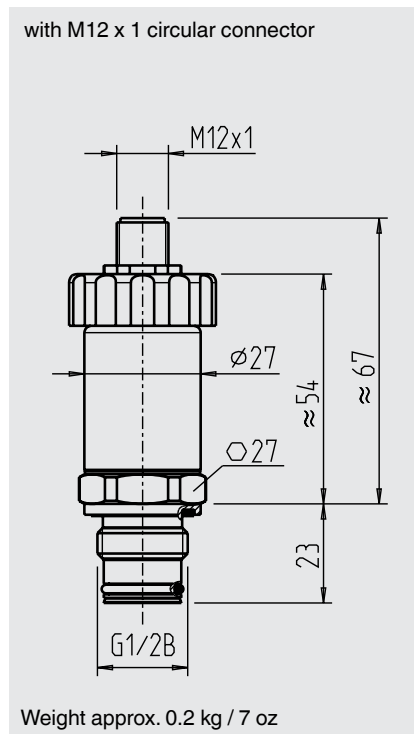
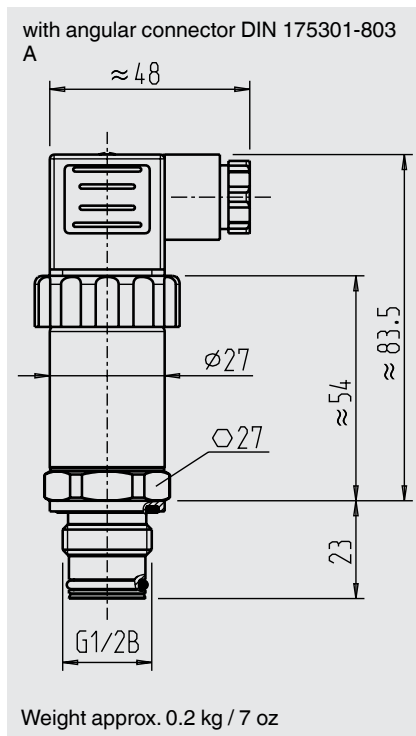

Process connections

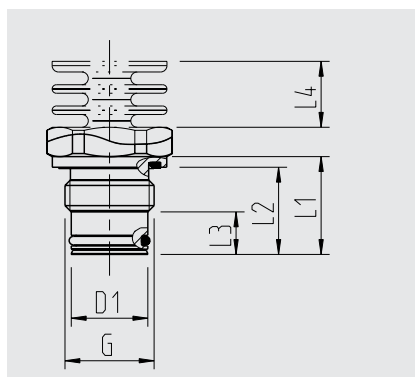

G	D1	L1	L2	L3	L4
G 1/2 B	18	23	20.5	10	15.5
	(0.71)	(0.91)	(0.81)	(0.4)	(0.61)

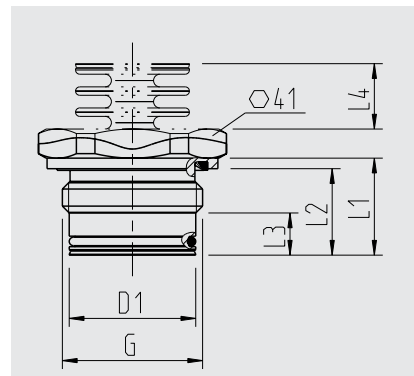

G	D1	L1	L2	L3	L4
G 1 B	30	23	20.5	10	15.5
	(1.19)	(0.91)	(0.81)	(0.4)	(0.61)

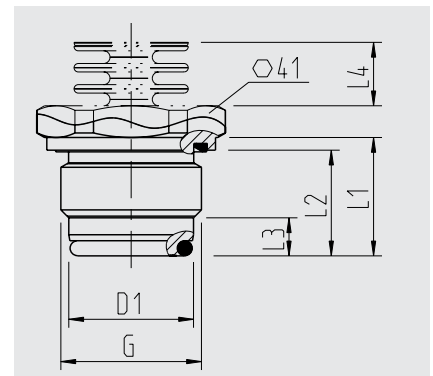

G	D1	L1	L2	L3	L4
G 1 B hygienic	29.5	28	25	9	15.5
	(1.17)	(1.11)	(0.99)	(0.36)	(0.61)

For information on tapped holes and welding sockets, see Technical information IN 00.14 at www.wika.com.

Accessories

Welding socket

	Designation	Order no.
	Welding socket for G 1/2 B flush	1192299
Welding socket for G 1 B flush	1192264	
Welding socket for G 1 B hygienic flush	14070973	
Welding socket for G 1 B hygienic flush with leak-control channel	14070974	

Further adapter systems for for measuring instruments with process connection G 1 B hygienic, see data sheet AC 09.20.

Mating connector

Designation	Order no.			
	without cable	2 m cable, shielded	5 m cable, shielded	10 m cable, shielded
Angular connector DIN 175301-803 A				
■ with cable gland, metric	11427567	14100465	14100466	-
■ with cable gland, conduit	11022485	-	-	-
Circular connector M12 x 1 (4-pin)				
■ straight	-	14086880	14086883	14086884
■ angled	-	14086889	14086891	14086892

Sealings for mating connectors

Mating connector	Order no.	
	Blue (WIKA)	Brown (neutral)
Angular connector DIN EN 175301-803 A	1576240	11437902

Sealings for process connection

Thread size and sealing	Order no.		
	NBR	FPM/FKM	EPDM
G 1/2 B			
■ O-ring	14072275	14072276	14072277
■ Profile sealing	1039067	1039075	1538306
G 1 B			
■ O-ring	1108247	1099094	1535056
■ Profile sealing	1100386	1145967	11522381
G 1 B hygienic			
■ O-ring	-	-	2225859
■ Profile sealing	-	-	11522381

Ordering information

Model / Measuring range / Output signal / Accuracy / Electrical connection / Medium temperature / Process connection / Sealing / System fill fluid

© 2012 WIKA Alexander Wiegand SE & Co. KG, all rights reserved.
The specifications given in this document represent the state of engineering at the time of publishing.
We reserve the right to make modifications to the specifications and materials.



WIKAL Instrument Corporation
1000 Wiegand Boulevard
Lawrenceville, GA 30043-5868
Tel: 888-WIKA-USA • 770-513-8200
Fax: 770-338-5118
E-Mail: info@wika.com
www.wika.com