

7. Auto-manual control (A-M)

- 1) Auto control only**
The initial setting is auto control, menu A-M is set as "AUTO".
- 2) Manual control only**
(a) Enter user setup mode, set the menu A-M as "MAN".
(b) After return back to operation mode, SV window will display the output percentage: M0~M100 (corresponding to 0%~100%), press UP key or DOWN key to modify the value.
(c) After the meter is powered on again, the manual control output percentage before power failure can be restored.
- 3) Auto-manual control shortcut switch**
(a) Enter user setup mode, set the menu A-M as "AM".
(b) After return back to operation mode, pressing "SET" key can switch the operation between auto control and manual control easily.
(c) When it is switched to manual control, SV window will display the output percentage: M0~M100 (corresponding to 0%~100%), press UP key or DOWN key to modify the value.
(d) Before the switch from manual control to auto control, in order to ensure the smooth switch, please press "K" key to modify the SV value first.
(e) After the meter is powered on again, manual control mode will be restored, and the output percentage will be 0%.

8. Alarm output (AD1, AL1, HY1, AE1, AD2, AL2, HY2, AE2)

- TE series supports 2 alarm outputs (AL1 and AL2). These two alarms can work independently or work together as a combination, total 12 different types of alarm functions.
- 1) No alarm**
Enter user setup mode, set alarm mode (AD1, AD2)=0, alarm function will be closed.
 - 2) Independent alarm**
(a) When AD1=1~6, AD2=1~6, alarm AL1 and AL2 are used as two independent alarm, both AL1 and AL2 will output.
(b) Refer to below alarm output logic and set SV value "Δ", alarm value (AL1, AL2) "▲", alarm hysteresis (HY1, HY2) "☆" according to the actual usage.
Note ※: For deviation alarm, if alarm value (AL) is set as a negative number, it will be used as an absolute value.

AD1/AD2 value	Alarm mode	Illustration	Alarm logic: the hatched section means the alarm action
1	High limit absolute alarm		When PV>AL, alarm output turns on. When PV<AL-HY, alarm output turns off.
2	Low limit absolute alarm		When PV<AL, alarm output turns on. When PV>AL+HY, alarm output turns off.
3	High limit deviation alarm		When PV>SV+AL, alarm output turns on. When PV<SV+AL-HY, alarm output turns off.
4	Low limit deviation alarm		When PV<SV-AL, alarm output turns on. When PV>SV-AL+HY, alarm output turns off.
5	High/low limit deviation alarm		When PV>SV+AL or PV<SV-AL, alarm output turns on. When SV-AL+HY<PV<SV+AL+HY, alarm output turns off.
6	High/low limit interval alarm		When SV-AL<PV<SV+AL, alarm output turns on. When PV<SV-AL+HY or PA>SV+AL+HY, alarm output turns off.

- 3) Combination alarm**
(a) When AD1=7~12, AD2 can be set as 0 only, alarm AL1 and AL2 are used as a combination alarm, AL1 outputs, AL2 does not output.
(b) Refer to below alarm output logic and set SV value "Δ", alarm value (AL1, AL2) "▲", alarm hysteresis (HY1, HY2) "☆" according to the actual usage.
Note ※: For deviation alarm, if alarm value (AL) is set as a negative number, it will be used as an absolute value.

AD1 value	Alarm mode	Illustration	Alarm logic: the hatched section means the alarm action
7	High and low limit absolute value interval alarm		When AL1<PV<AL2, alarm output turns on. When PV<AL1-HY1 or PV>AL2+HY2, alarm output turns off.
8	High and low limit deviation value interval alarm		When SV-AL1<PV<SV+AL2, alarm output turns on. When PV<SV-AL1-HY1 or PV>SV+AL2+HY2, alarm output turns off.
9	High limit absolute value and low limit deviation value interval alarm		When AL1<PV<SV+AL2, alarm output turns on. When PV<AL1-HY1 or PV>SV+AL2+HY2, alarm output turns off.
10	High limit absolute value and low limit deviation value interval alarm		When PV<AL1 or PV>AL2, alarm output turns on. When PV>AL1+HY1 or PV<AL2-HY2, alarm output turns off.
11	High/low limit absolute value alarm		When PV<AL1 or PV>AL2, alarm output turns on. When PV>AL1+HY1 or PV<AL2-HY2, alarm output turns off.
12	High/low limit deviation value alarm		When PV<SV-AL1 or PV>SV+AL2, alarm output turns on. When PV>SV-AL1+HY1 or PV<SV+AL2-HY2, alarm output turns off.

- 4) Alarm hold operation**
Set AE1 & AE2 to choose the alarm operation method when the meter displays error (HHHH/LLLL), and the low alarm hold operation when the power is supplied.

AE1/AE2 set value	Alarm operation when the meter displays error code(HHHH/LLLL)	Low alarm hold operation after power on
0	Alarm operation keeps the same state before the error is displayed.	No alarm hold operation.
1	Alarm output turns on even during alarm cancel condition.	After power on and temperature increases, low alarm output turns on immediately when the alarm condition is reached.
2	Alarm output turns off even during alarm condition.	
3	Alarm operation keeps the same state before the error is displayed.	Alarm hold operation.
4	Alarm output turns on even during alarm cancel condition.	After power on and temperature increases, low alarm output is prevented from turning on until PV value reaches SV value for the first time.
5	Alarm output turns off even during alarm condition.	After that alarm works normally, it will not be held.

9. User setup mode

User setup mode is the mode that sets the set values changed by users frequently. The parameters of the operator setup mode are also displayed in the user setup mode, so that they can be easily set. In the operation mode, press and hold "SET" key for 3 sec to enter the user setup mode. Press and hold "SET" key for 3 sec again to return to the operation mode.

Symbol (PV)	Name	Content	Initial value (SV)	Display condition
AL1	Alarm 1 value	FL (measure range low limit) ~ FH (measure range high limit) Note: For deviation alarm, if AL1 is set as a negative number, it will be used as an absolute value.	10	Always displayed
HY1	Alarm 1 hysteresis	0~1000	1	
AD1	Alarm 1 mode (Refer to alarm logic diagram)	AL1 & AL2 are independent from each other AL1 & AL2 are used in combination AL1 output, AL2 not output, AD2=0	3	
AL2	Alarm 2 value	FL (measure range low limit) ~ FH (measure range high limit) Note: For deviation alarm, if AL2 is set as a negative number, it will be used as an absolute value.	5	
HY2	Alarm 2 hysteresis	0~1000	1	
AD2	Alarm 2 mode	AL1 & AL2 are independent from each other	4	
PS	PV bias value	Use this function to adjust PV value in cases where it is necessary for PV value to agree with another indicator, or when the sensor cannot be mounted in correct location. Setting range: FL (measure range low limit) ~ FH (measure range high limit) PV = actual measured value + bias value	0	
INP	Input type	TE-W K : K thermocouple J : J thermocouple E : E thermocouple T : T thermocouple B : B thermocouple R : R thermocouple S : S thermocouple N : N thermocouple PT : PT100 RTD JPT : JPT100 RTD CU50 : CU50 RTD CU100 : CU100 RTD 0~50mV 0~400V TE-XW PT : 4~20mA 0~10V Note: after selecting the signal, pls properly set below related parameters: SV, AL1, HY1, AL2, HY2, P, OVS, DB.	K	
OT	Control type	0: ON/OFF heating control 1: PID heating control 2: ON/OFF cooling control 3: PID heating & cooling control (cooling control OUT2 will output via AL1 relay) 4: ON/OFF over temperature cooling control 5: PID cooling control	1	
A-M	Auto-manual control switch	AUTO(0): auto control only MAN(1): manual control only AM(2): auto-manual shortcut switch	AUTO	
p	Proportional band	0~9999, unit: same as PV The smaller the value is, the faster the system responds, otherwise, it is slower. When P=0, no PID control.	30	
I	Integral time	0~9999 sec The smaller the value is, the stronger the integral action is, otherwise, it is weaker. When I=0, no integral action.	120	
D	Derivative time	0~9999 sec The greater the value is, the stronger the differential action is, otherwise, it is weaker. When D=0, no differential action. Set D=0 when controlling fast systems, e.g., pressure, speed.	30	
OVS	Overshoot limit	0~9999 During PID control process, if PV>SV+OVS, force to close output. The smaller this value is, the smaller the PID adjustment range is, the worse the control stability is. Please set the appropriate value according to the actual situation.	5	
CP	OUT1 control output cycle	1 sec: SSR control output 4~200 sec: Relay control output	20	
CP1	OUT2 relay output cycle	4~200 sec	20	
PC	OUT2 cooling proportional coefficient	1~100 The higher of value, the stronger of cooling effect.	10	

Symbol (PV)	Name	Content	Initial value (SV)	Display condition
DB	ON/OFF control hysteresis	-1000~1000 (positive and negative numbers work the same). When OT=3, it is the dead zone for cooling control (positive and negative numbers work differently). After change the INP setting, please change this parameter according to the decimal point position.	5	With ON/OFF control and PID heating & cooling control type
LCK	Lock function	0~9999 0001: SV value cannot be modified. 0010: menu can be checked only, cannot be modified. 0011: both SV value and menu can be checked only, cannot be modified. 0033: can enter to operator setup mode. 0123: menus are reset to initial value.	0	Always displayed

10. Operator setup mode

Operator setup mode is the setting mode that sets the specifications of the temperature controller when the engineer installs it for the first time.
In the user setup mode, set the menu LCK = 0033 to enter the operator setup mode.

Symbol (PV)	Name	Content	Initial value (SV)	Display condition	
ACT	Control output type	0: Relay contact output. 1: SSR drive voltage output. 2: 4~20mA current control output 3: 4~20mA retransmission output for size 3/4/7 products. Note: For size 6/8/9 products, when this menu is set as 0 or 1, 4-20mA output is used as retransmission output.	0	Always displayed	
AE1	AL1 hold operation	0~5 AL1 operation when power on and meter displays error.	0	When there are 2 alarm outputs.	
AE2	AL2 hold operation	0~5 AL2 operation when power on and meter displays error.	0		
DP	Decimal point setting	TC & RTD signal: 0~1 decimal place. Linear signal: 0~3 decimal place.	0	Always displayed	
DTR	PV value fuzzy display	0.0~2.0 (0%~20%) Properly set this value on some occasions, it can get a more stable display value, this value is not the actual measured value. Note: after setting this value, when alarm setting value is equal to SV set value, alarm output operation is subject to actual measured value. Set as 0 to close this function.	1.0 (10%)		
FT	PV filter	0~255 When PV value becomes unstable due to effects of noise, the filter helps suppress the unstable status. The higher of the value, the stronger of the filter function.	10		
UT	Temperature unit	(25)°C: Celsius degrees. (26)°F: Fahrenheit degrees. Note: No unit for linear signal	(25) °C		
FL	Measure range low limit	Setting range: refer to "IV. Ranges and Input Types" on page 2. Set value must be less than FH.	-50		
FH	Measure range high limit	Setting range: refer to "IV. Ranges and Input Types" on page 2. Set value must be greater than FL.	1200		
BRL	Retransmission low limit	FL (measure range low limit) ~ FH (measure range high limit) Note: when this value is greater than BRH, it is used as reverse retransmission.	-50		With retransmission output.
BRH	Retransmission high limit	FL (measure range low limit) ~ FH (measure range high limit) Note: when this value is less than BRL, it is used as reverse retransmission.	1200		
OLL	Current control output low limit	-5.0~100.0 Set value must be less than OLH.	0		With current control output.
OLH	Current control output high limit	0.0~105.0 Set value must be greater than OLL.	100.0		
ST	Auto-tuning activation right after power-on	0: work normally after power-on, 1: automatically enter PID auto-tuning mode right after the power is supplied, press and hold "K" key to exit auto-tuning mode.	0		
SPD	PID control speed	0 (N): not using 1 (s): slow 2 (ss): medium slow 3 (SSS): very slow 4 (F): fast 5 (FF): medium fast 6 (FFF): very fast	0 (N)		With PID control type
PDC	PID algorithm control type	0 (FUZ): Advanced fuzzy PID algorithm control 1 (STD): normal PID algorithm control	0 (FUZ)	With compressor cooling control type	
PT	Compressor start delay time	0~9999 sec	0		
BAD	Communication baud rate	0 (4.8): 4800 1 (9.6): 9600 2 (19.2): 19200	1 (9.6)		
ADD	Communication address	0~255	1		
PRTY	Parity check	0: NO 1: ODD 2: EVEN	0 (NO)	With RS485 Comm.	
DTC	Communication data transfer sequence (000)	Set value □:□:□ Content 1st bit 0 : Function reserved 2nd bit 0 : Transfer sequency is 1, 2. Byte transfer sequency 1 : Transfer sequency is 2, 1. 3rd bit 0 : Function reserved	0		

Symbol (PV)	Name	Content	Initial value (SV)	Display condition
CAE	Linear signal calibration	0(N): not using 1(Y): enable the calibration value	0 (N)	With linear signal input
CAL	Calibration low limit	YES/OK	YES	
CAH	Calibration high limit	YES/OK	YES	
VER	Version	Software version code	—	

11. Fault diagnosis

- After power on, the meter is not working, there is no display, the possible causes are:
 - The wiring of the power supply is incorrect, or the contact of the power supply terminals is poor.
 - The auxiliary power is short circuited.
- Inaccurate PV value.
 - PV bias value (PS) is not set correctly.
 - The wiring of the temperature sensor is incorrect.
 - The input signal type (INP) is not set correctly.
- When PV window displays HHHH/LLLL, the possible causes are:
 - The temperature sensor is not connected to the meter, or the wiring is incorrect.
 - The input signal type (INP) is not set correctly.
 - The temperature sensor is broken.
 - Poor contact of the input terminals.
 - The meter is broken.

VIII. Parameter configuration

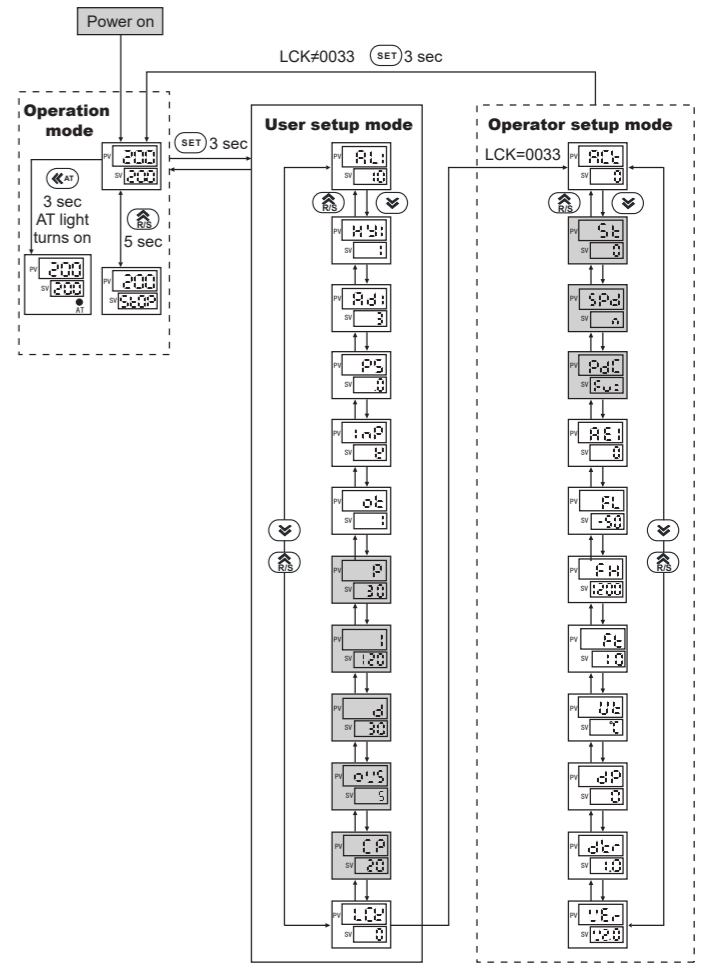

IX. Connection diagrams

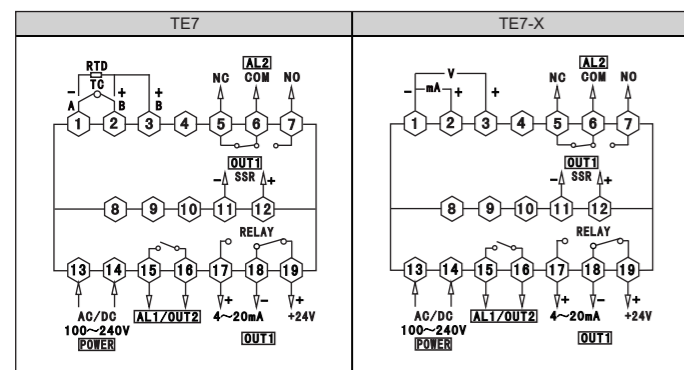
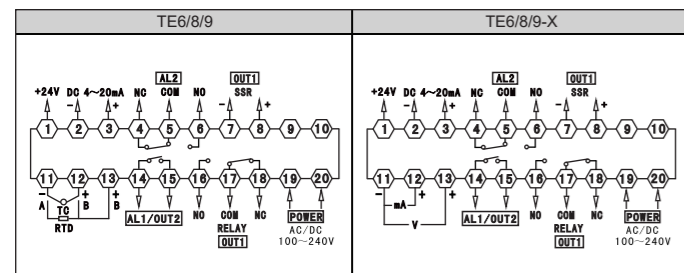
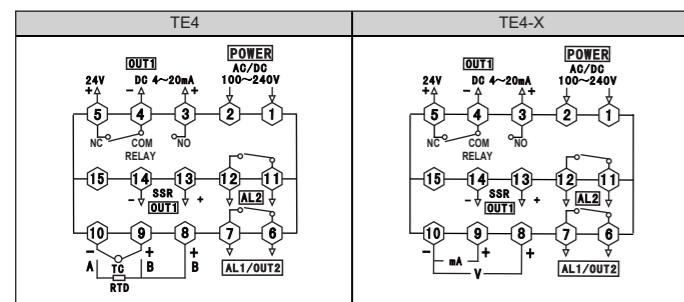
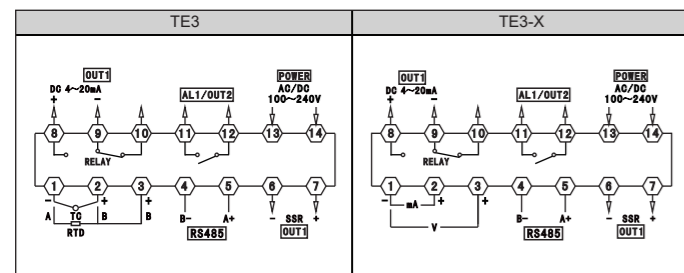

Note: If there is any change, please subject to the drawing on the meter.

X. Isolation diagram

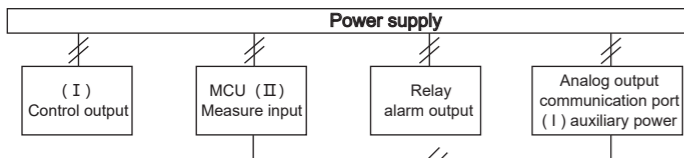

"//": Isolation

Note: When the auxiliary power supply between (I) & (II) is used as the power supply for external sensor, if the sensor is non-isolated, it does not isolate.

XII. Communication protocol

Meter adopts RS485 Modbus RTU communication protocol, RS485 half duplex communication. Read function code 0x03, write function code 0x10 or 0x06. Adopt 16 digit CRC check, the meter does not return for error check.

Data frame format:

Start bit	Data bit	Stop bit	Check bit
1	8	1	Set in Menu PRTY

Handling of abnormal communication:

When abnormal response, put 1 on the highest bit of function code. For example: Host request function code 0x03, and slave response function code should be 0x83.

Error code:

0x01--- Illegal function: the function code sent from host is not supported by meter.

0x02--- Illegal address: the register address designated by host beyond the address range of meter.

0x03--- Illegal data: Date value sent from host exceeds the corresponding data range of meter.

Communication cycle:

Communication cycle is the time from host request to slave response data, i.e.: communication cycle= time of request data sending +slave preparation time + response delay time + response return time, e.g.: 9600 Baud rate: communication cycle of single measured data ≥250ms.

1. Read register

For example: Host reads integer SV (set value 200)

The address code of SV is 0x2000, because SV is integer (2 byte), seizes 1 data register. The memory code of decimal integer 200 is 0x00C8. Note: when reading data, should read DP value or confirm DP menu value first to ensure the decimal point position, after that transform the read data to get the actual value. Conversely, it should transform the data to corresponding ratio before writing the data in meter.

Host request (Read multi-register)							
1	2	3	4	5	6	7	8
Meter ADD	Function code	Start ADD High bit	Start ADD Low bit	Data byte Length high bit	Data byte Length low bit	※CRC code low bit	※CRC code high bit
0x01	0x03	0x20	0x00	0x00	0x01	0x8F	0xCA

Slave normal answer(Read multi-register)						
1	2	3	4	5	6	7
Meter ADD	Function code	Data byte Length	Data high bit	Data low bit	※CRC code low bit	※CRC code high bit
0x01	0x03	0x02	0x00	0xC8	0xB9	0xD2

Function code abnormal answer: (For example: host request ADD is 0x2011)

Slave abnormal answer(Read multi-register)				
1	2	3	4	5
Meter ADD	Function code	Error code	※CRC code low bit	※CRC code high bit
0x01	0x83	0x02	0xC0	0xF1

2. Write multi-register

For example: Host use 0x10 function code write SV (set value 150)

ADD code of SV is 0x2000, because SV is integer (2 byte), seizes 1 data register.

The hexadecimal code of decimal integer 150 is 0x0096.

Host request (write multi-register)										
1	2	3	4	5	6	7	8	9	10	11
Meter ADD	Function code	Start ADD High bit	Start ADD Low bit	Data byte Length high bit	Data byte Length low bit	Data byte Length	Data low bit	Data low bit	※CRC code low bit	※CRC code high bit
0x01	0x10	0x20	0x00	0x00	0x01	0x02	0x00	0x96	0x07	0xFC

Slave normal answer (write multi-register)							
1	2	3	4	5	6	7	8
Meter ADD	Function code	Start ADD High bit	Start ADD Low bit	Data byte length high bit	Data byte length low bit	※CRC code low bit	※CRC code high bit
0x01	0x10	0x20	0x00	0x00	0x01	0x0A	0x09

Host write SV with 0x06 function (set value 150)

Host request (write single-register)							
1	2	3	4	5	6	7	8
Meter ADD	Function code	Start ADD High bit	Start ADD Low bit	Data high bit	Data low bit	※CRC code low bit	※CRC code high bit
0x01	0x06	0x20	0x00	0x00	0x96	0x02	0x64

Slave normal answer (write single-register)							
1	2	3	4	5	6	7	8
Meter ADD	Function code	ADD High bit	ADD Low bit	Data high bit	Data low bit	※CRC code low bit	※CRC code high bit
0x01	0x06	0x20	0x00	0x00	0x96	0x02	0x64

Slave abnormal answer (write single-register)				
1	2	3	4	5
Meter ADD	Function code	Error code	※CRC code low bit	※CRC code high bit
0x01	0x86	0x02	0xC3	0xA1

Meter parameters address mapping table

No.	Add (Register No.①)	Variable name	Register	R/W	Remark
1	0x2000 (48193)	Set value SV	1	R/W	
2	0x2001 (48194)	Alarm 1 value AL1	1	R/W	
3	0x2002 (48195)	Alarm 1 hysteresis HY1	1	R/W	
4	0x2003 (48196)	Alarm 2 value AL2	1	R/W	
5	0x2004 (48197)	Alarm 2 hysteresis HY2	1	R/W	
6	0x2005 (48198)	Measure range low limit FL	1	R/W	
7	0x2006 (48199)	Measure range high limit FH	1	R/W	
8	0x2007 (48200)	Retransmission output low limit BRL	1	R/W	
9	0x2008 (48201)	Retransmission output high limit BRH	1	R/W	

No.	Add (Register No.①)	Variable name	Register	R/W	Remark
10	0x2009 (48202)	Current control output low limit OLL	1	R/W	Default 1 decimal place
11	0x200A (48203)	Current control output high limit OLH	1	R/W	Default 1 decimal place
12	0x200B (48204)	Overshoot limit OVS	1	R/W	
13	0x200C (48205)	Heat & Cool control dead zone DB	1	R/W	
14	0x200D (48206)	OUT2 cooling proportional coefficient PC	1	R/W	Default 1 decimal place
15	0x200E (48207)	PV bias value PS	1	R/W	
16	0x200F (48208)	PV value fuzzy display DTR	1	R	Engineering work without decimal point
17	0x2010 (48209)	Present value PV	1	R	
18	0x2011 (48210)	Output percentage MV	1	R/W	0~100
19	0x2012 (48211)	Auto-Manual control A-M	1	R/W	0: Auto 1: Manual

Reserve					
20	0x2100 (48449)	Alarm 1 mode AD1	1	R/W	
21	0x2101 (48450)	Alarm 2 mode AD2	1	R/W	
22	0x2102 (48451)	Alarm 1 hold operation AE1	1	R/W	
23	0x2103 (48452)	Alarm 2 hold operation AE2	1	R/W	
24	0x2104 (48453)	Control type OT	1	R/W	
25	0x2105 (48454)	Control output type ACT	1	R/W	
26	0x2106 (48455)	RUN/STOP operation	1	R/W	1:RUN 2:STP 3:Run auto-tune 4:Stop auto-tune
27	0x2107 (48456)	Decimal point DP	1	R/W	
28	0x2108 (48457)	Temperature unit UT	1	R/W	25 (°C) 26 (°F)
29	0x2109 (48458)	PV filter FT	1	R/W	
30	0x210A (48459)	Proportional band P	1	R/W	No decimal point
31	0x210B (48460)	Integral time I	1	R/W	No decimal point
32	0x210C (48461)	Derivative time D	1	R/W	No decimal point
33	0x210D (48462)	Control speed SPD	1	R/W	
34	0x210E (48463)	OUT1 control output cycle CP	1	R/W	No decimal point
35	0x210F (48464)	OUT2 control output cycle CP1	1	R/W	No decimal point
36	0x2110 (48465)	Compressor start delay time PT	1	R/W	No decimal point
37	0x2111 (48466)	Input type INP	1	R/W	Refer to signal table
38	0x2112 (48467)	Meter address ADD	1	R/W	
39	0x2113 (48468)	Communication baud rate BAD	1	R	
40	0x2114 (48469)	Communication data transfer sequence DTC	1	R	Note ③
41	0x2115 (48470)	PID algorithm control type PDC	1	R	
42	0x2116 (48471)	Lock LCK	1	R	
43	0x2117 (48472)	Meter name	1	R	
44	0x2118 (48473)	Output state	1	R	Note ②
48	0x2119 (48474)	Parity Check PRTY	1	R	

R: Read only; R/W: Read & write

Note①: The register number is the address converted to decimal plus 1 and then the register identification code 4 is added in front; for example: the register number of the data address 0x2000 is 8192 + 1 = 8193 and then 4 is added in front, that is, the register number 48193; Related applications can be seen, such as Siemens S7-200 PLC.

Note ②: Measurement status indication. When the data bit is 1, it means execution, and when it is 0, it means no execution.

D7	D6	D5	D4	D3	D2	D1	D0
STOP	HHHH	LLLL	AT	AL2	AL1	OUT2	OUT1

Note③: DTC communication data transfer sequence description

Set value	Content
1st bit 0	Function reserved
2nd bit 0	Transfer frequency is 1, 2.
Byte transfer frequency 1	Transfer frequency is 2, 1.
3rd bit 0	Function reserved

※16-bit CRC check code to get C program
unsigned int Get_CRC(uchar *pBuf, uchar num)

```

unsigned ij;
unsigned int wCrc = 0xFFFF;
for(i=0; i<num; i++)
{
    wCrc ^= (unsigned int)(pBuf[i]);
    for(j=0; j<8; j++)
    {
        if(wCrc & 1){wCrc >>= 1; wCrc ^= 0xA001;}
        else wCrc >>= 1;
    }
}
return wCrc;

```